



INSTALLATION INSTRUCTIONS

Accessory
SIDE STEPS
 P/N 08L33-SJC-100C (Chrome)
 08L33-SJC-100D (Black)
 08L33-SJC-100E (Silver)

Application
2014 RIDGELINE

Publications No.
All 50357
 Issue Date
AUG 2013

PARTS LIST

Left side step

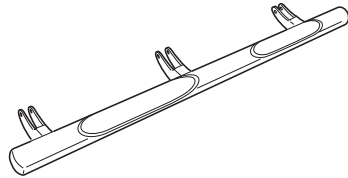

Right side step

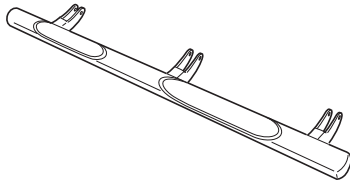

4 Brackets A

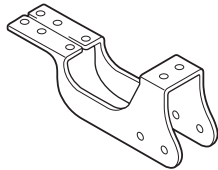

2 Brackets B



46 Flange bolts



24 Flange nuts



2 Knurled threaded inserts



TOOLS AND SUPPLIES REQUIRED

- Ratchet
- 13 mm Socket
- Extension
- 13 mm Combination wrench
- Blanket
- Torque wrench
- Clip remover
- Rivet nut installation tool (8 mm) T/N: LEM722M8
- 27 mm Wrench

INSTALLATION

Customer Information: The information in this installation instruction is intended for use only by skilled technicians who have the proper tools, equipment, and training to correctly and safely add equipment to your vehicle. These procedures should not be attempted by "do-it-yourselfers".

NOTE:

- Clean the bottom of the body from the rear of the front wheels forward to the front of the rear wheels.
 - Be careful not to damage the paint finish. To prevent damage, place a blanket under the side step during the installation.
 - These instructions show the left side being installed; the same procedure applies to installing the right side step.
1. Under the vehicle, locate and remove the grommet from the body. Do steps 2 through 5 to install the knurled threaded insert into the grommet hole.

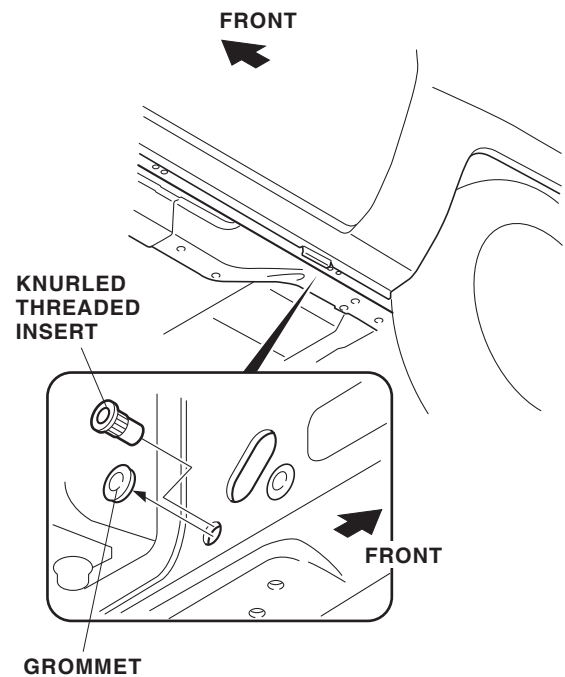

2. Screw the knurled threaded insert onto the mandrel of the tool as shown.

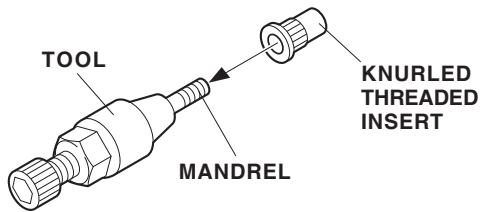

3. Insert the knurled threaded insert into the hole in the vehicle panel and install the hex wrench on the tool.

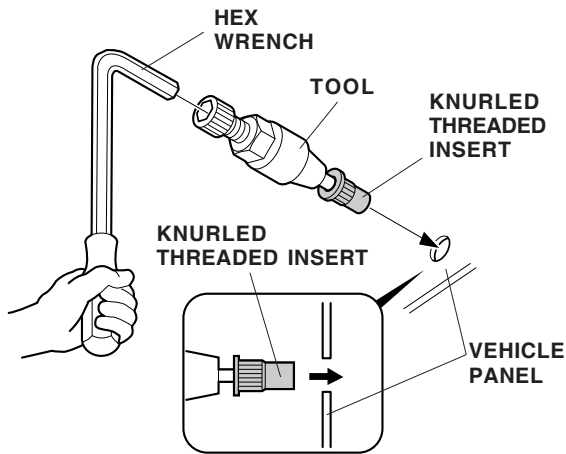

4. Holding the tool with the hex wrench, turn the 27 mm wrench clockwise and install the knurled threaded insert in the vehicle panel.

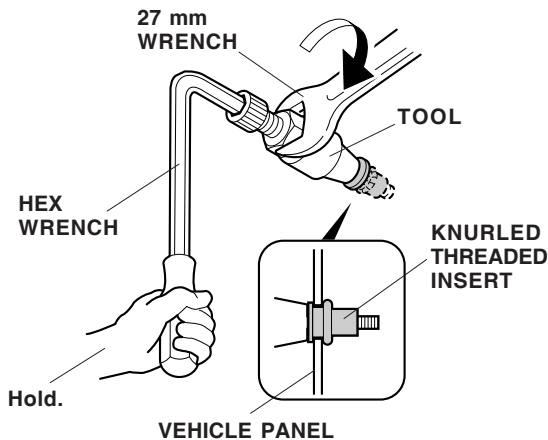

5. Remove the tool from the knurled threaded insert by turning the hex wrench counterclockwise.

6. Remove and discard the six clips from the bottom of the body.

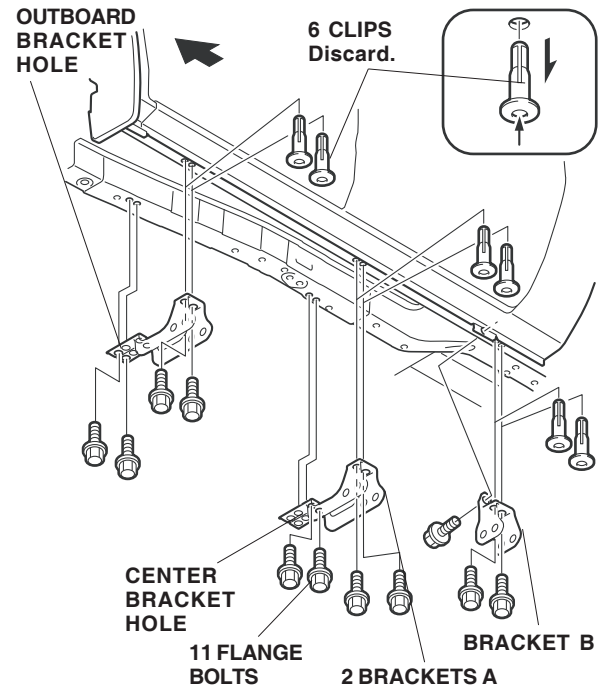

7. Install two brackets A and one bracket B to the body using 11 flange bolts. Thread the flange bolts in about 3 to 4 threads. When installing brackets A, use the outboard bracket holes for the front bracket, and the center bracket holes for the center bracket.

- Install the side step to the brackets using 12 flange bolts and 12 flange nuts. Thread the nuts on about 3 to 4 threads.

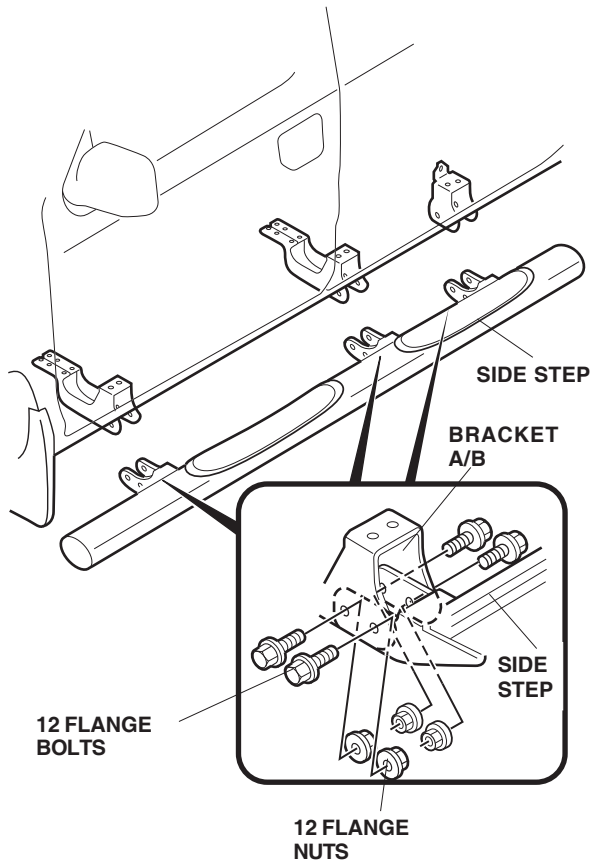

- Adjust the location of the left side step so there is even clearance between the side step and body, then tighten the flange bolts you installed in step 7. Torque 10 flange bolts to 27 N·m (20 lb·ft), and the one remaining flange bolt to 7 N·m (5 lb·ft) as shown.

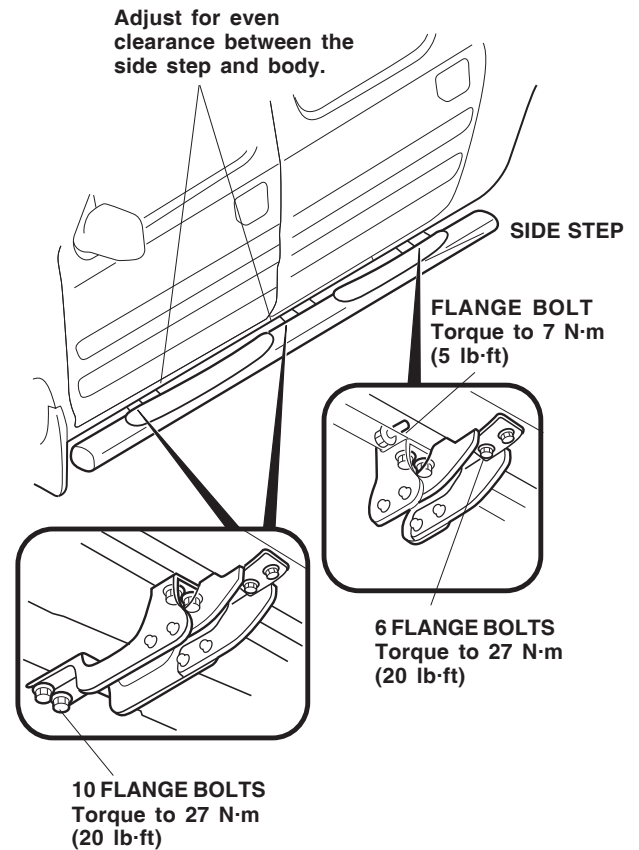

- Tighten the 12 flange bolts you installed in step 8 to 27 N·m (20 lb·ft).
- Tighten the 6 flange bolts pre-installed on the side step to 27 N·m (20 lb·ft)
- Repeat steps 1 through 11 to install the side step on the right side of the vehicle.